

Technical data sheet



Product features

Electric fryer 0,96 kW/l, 13 l without cabinet 400 V

Model	SAP Code	00110050
--------------	-----------------	----------



- Basin volume [l]: 13
- Drain type: On the front panel
- Drain: Yes
- Maximum device temperature [°C]: 190
- Minimum device temperature [°C]: 50
- Material: Stainless steel
- Heating location: Inside the tank
- Number of baskets: 1
- Basket size [mm]: 280 x 295 x 100

SAP Code	00110050	Power gas [kW]	12.000
Net Width [mm]	400	Basin volume [l]	13
Net Depth [mm]	700	Number of basins	1
Net Height [mm]	330	Number of baskets	1
Net Weight [kg]	22.00	Basket size [mm]	280 x 295 x 100
Power electric [kW]	12.500	Ratio power/volume [kW/l]	0.96
Loading	400 V / 3N - 50 Hz		

Technical data sheet



Technical drawing

Electric fryer 0,96 kW/l, 13 l without cabinet 400 V

Model	SAP Code	00110050
-------	----------	----------

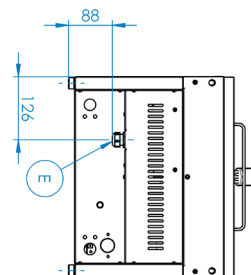
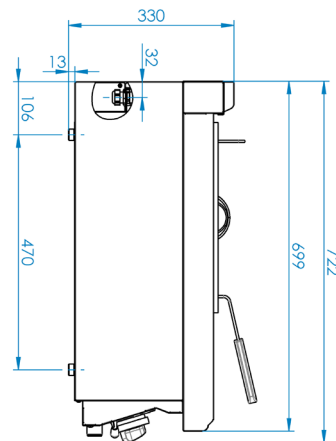
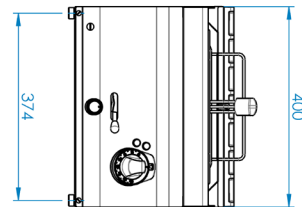

Technical data sheet



Product benefits

Electric fryer 0,96 kW/l, 13 l without cabinet 400 V

Model

SAP Code

00110050

1

All-stainless steel bathtub

long life
resistance of AISI 304 stainless steel material
the material does not cut

- savings on service interventions
- easier and faster operation

2

Degree of protection of the control elements IPX4

maintenance-free system
resistance to splash water
long life

- savings on service interventions
- easy cleaning and maintenance of equipment

3

Drain valve 3/4" in the front part of the device with a safety lock against self-draining

outlet of the bath into the prepared container

- easy and safe handling

4

Cold zone

prevents food residues from burning
there is no change in the taste of the oil

- longer oil life
- easy access and maintenance

5

Rotating heating element

longer lifetime
easy access

- effective cleaning when the body is tipped out
- easy access even to corners and time saving

6

High power consumption/l

quick run-up to operating temperature after inserting the product

- food is not soaked in oil, tastes better and is ready sooner
- more production

Technical data sheet



Technical parameters

Electric fryer 0,96 kW/l, 13 l without cabinet 400 V

Model

SAP Code

00110050

1. SAP Code:

00110050

2. Net Width [mm]:

400

3. Net Depth [mm]:

700

4. Net Height [mm]:

330

5. Net Weight [kg]:

22.00

6. Gross Width [mm]:

440

7. Gross depth [mm]:

800

8. Gross Height [mm]:

500

9. Gross Weight [kg]:

28.00

10. Device type:

Electric unit

11. Construction type of device:

Table top

12. Power electric [kW]:

12.500

13. Loading:

400 V / 3N - 50 Hz

14. Power gas [kW]:

12.000

15. Protection of controls:

IPX4

16. Material:

Stainless steel

17. Worktop type:

Molded - comfortable cleaning maintenance

18. Worktop material:

Stainless steel

19. Worktop Thickness [mm]:

1.20

20. Device heating type:

Direct

21. Standard equipment for device:

lid and basket

22. Basin volume [l]:

13

23. Basin dimensions [mm x mm x mm]:

300 x 336 x 200

24. Maximum device temperature [°C]:

190

25. Minimum device temperature [°C]:

50

26. Safety thermostat:

Yes

27. Adjustable feet:

Yes

28. Heating element material:

AISI 304

Technical data sheet



Technical parameters

Electric fryer 0,96 kW/l, 13 l without cabinet 400 V

Model

SAP Code

00110050

29. Number of baskets:

1

30. Number of basins:

1

31. Basket size [mm]:

280 x 295 x 100

32. Basin material:

AISI 304 - High quality stainless steel

33. Ratio power/volume [kW/l]:

0.96

34. Drain type:

On the front panel

35. Drain:

Yes

36. Drain connection:

No

37. Heating location:

Inside the tank